

2200 Series Back Office Workstation Bundle

2200 Back Office Bundle Installation Guide

Thank you for selecting UTC RETAIL's innovative 2200 Series Back Office bundle solution!

This guide is designed to help you efficiently assemble the 2200 Series Back Office Bundle System.



2200 Series Back Office Workstation Bundle Installation Guide

This guide was prepared by UTC RETAIL to assist personnel with the installation of the bundle components. All attempts have been made to ensure that the information presented in this manual is correct. No liability, expressed or implied, will be assumed by UTC RETAIL or affiliates for damage resulting from the use of this information.

All rights reserved. No part of this document may be reproduced, stored in a retrieval system, or transmitted in any form or by any means, electronic or mechanical, including photocopying, recording, or otherwise, without the prior written permission of UTC RETAIL.

If a unit needs to be shipped to UTC RETAIL for repairs, please return it in the original packaging material and shipping container. If you have questions, please call UTC RETAIL's Technical Support at 1.800.349.0546.

This equipment has been tested and found to comply with the limits for a Class "A" digital device, pursuant to Part 15 of the FCC Rules. These limits are designed to provide reasonable protection against harmful interference when the equipment is operated in a commercial environment. This equipment generates, uses, and can radiate radio frequency energy and, if not installed and used in accordance with the instruction manual, may cause harmful interference to radio communications. Operation of this equipment in a residential area is likely to cause harmful interference, in which case the user will be required to correct the interference at his/her own expense.



WARNING: CMOS Battery Damage

Replace your system's CMOS RAM battery only with identical CR-2032 3V Lithium-Ion coin cell (or equivalent) battery type to avoid risk of personal injury or physical damage to your equipment. Always dispose of used batteries according to the manufacturer's instructions, or as required by the local ordinance (where applicable). Any damage due to not following this warning will void your equipment warranty.



All access to internal components is restricted to Authorized Service personnel only.

If applicable, the key for this device should be in the possession of Qualified Service Personnel Only and used for access by an Authorized and Qualified Service Person.

Table of Contents

2200 Series Back Office Workstation Bundle System Installation Guide	2
Product Information	3
Un-boxing the System.....	4
Installation.....	4
Powering On Your 2200 Series Back Office Workstation Bundle System	8
Troubleshooting Procedures.....	8

Product Information

You will find the following components inside the 2200 Series Back Office Workstation Bundle System Box:

- Safety Sheet
- 2200 Series Back Office Workstation unit (PC / logic device)
- A/C power cord for logic device
- LCD Display
- Keyboard
- Mouse

Note: The following optional items may or may not be present depending on the configuration purchased and may be shipped in a separate box.

- Inventory Scanner
- AC Power Conditioner
- Traffic Counter and Door Sensor
- Label / Ticket Printer

Un-boxing the System

1. Open the point of sale box and remove the contents.
2. Remove all packing materials.

Installation

1. Remove the LCD, LCD VGA video cable and power supply from the LCD box. Connect the LCD VGA (Video) cable to the Video Port (Blue) on the back of the PC.
2. Connect the power cable from the LCD power supply to the connector on the LCD Display. Connect the AC cable to the LCD power supply and then to a wall outlet or the optional Power Conditioner.

Figure 1: Bottom View of LCD and Rear View of PC

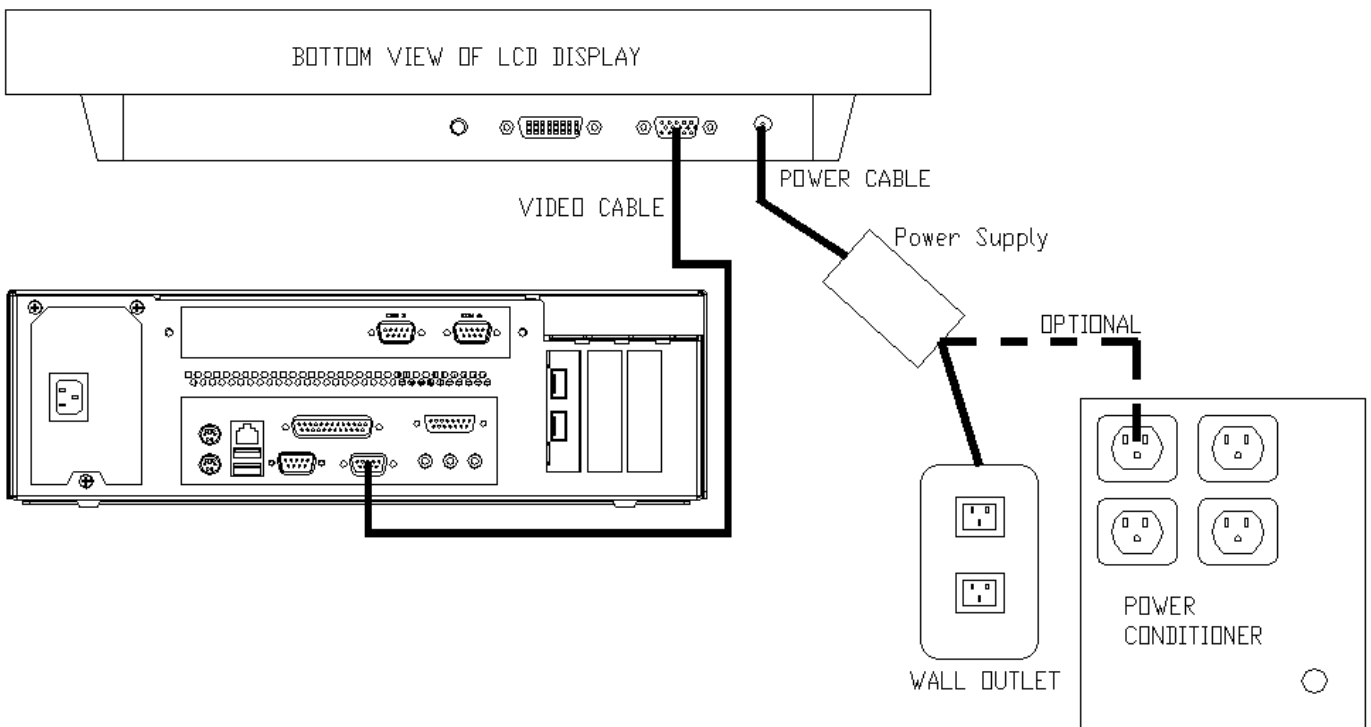

3. Connect the mouse and keyboard cables to the PC. The mouse port on the PC is green and the keyboard port is purple.

Figure 2: Rear View of PC and Top views of keyboard and mouse

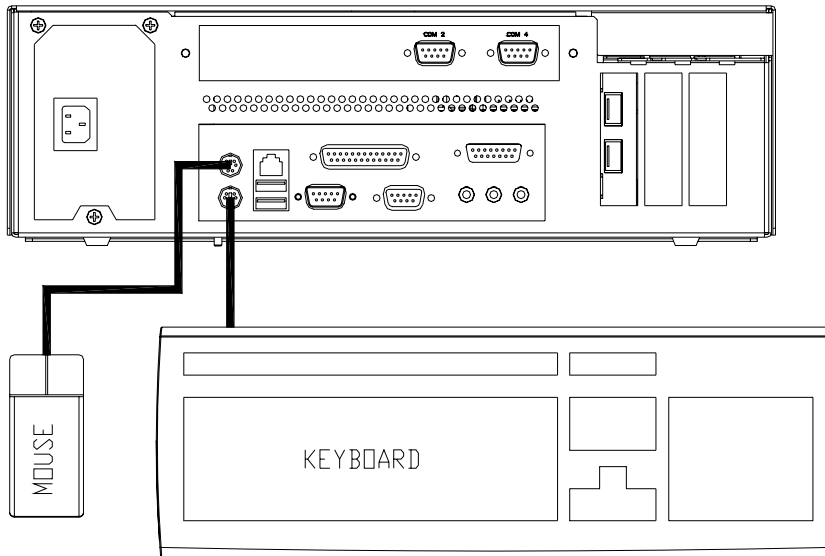

4. Label Printer option: Locate the printer data cable. Connect the DB25 end to the parallel port on the PC. Next connect the other end to the connector on the back of the label printer, and then close the clamps on each side. Finally, connect the power cable from the AC power supply to the back of the printer, and plug the AC cord into the wall outlet or optional Power Conditioner.

Figure 3: Rear View of Label Printer

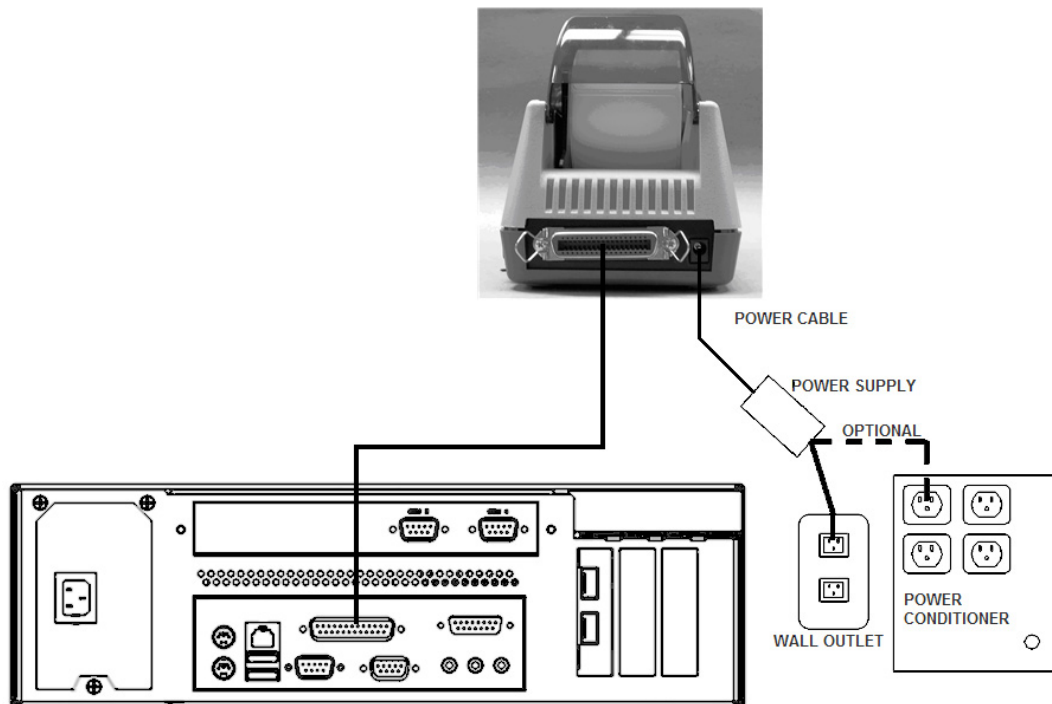

5. Inventory Scanner option: Locate the scanner data cable and connect to a serial port on the back of the PC. Connect the power connector to the scanner base and then plug the AC power adapter into a wall outlet or the optional Power Conditioner.

Figure 4: Rear View of PC and Top View of Inventory Scanner

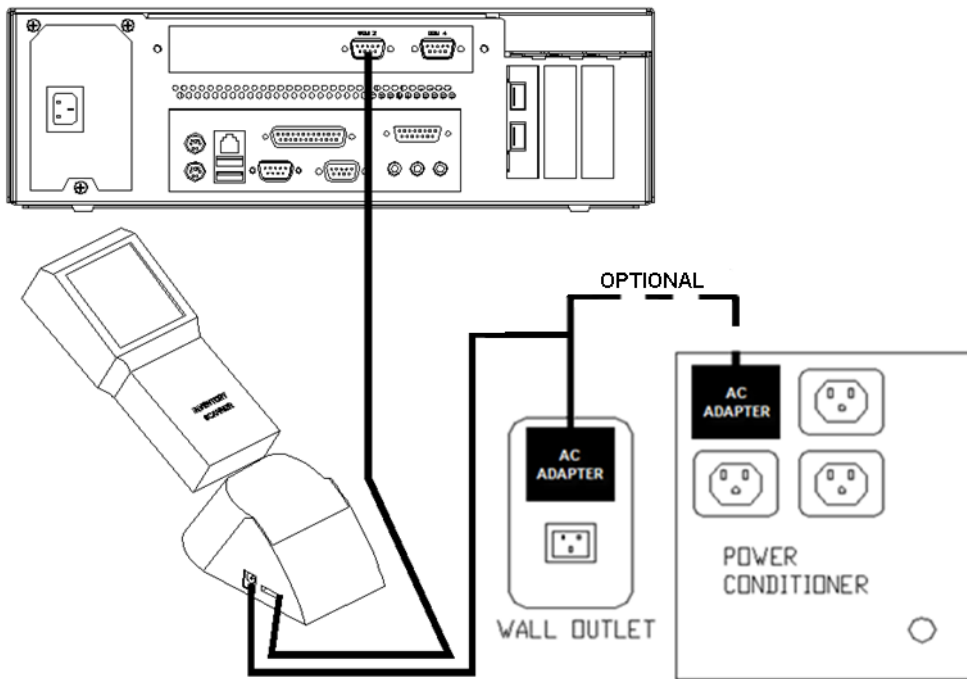

6. Connect a site provided network cable into the network jack on the back of the PC.

Figure 5: Rear View of PC

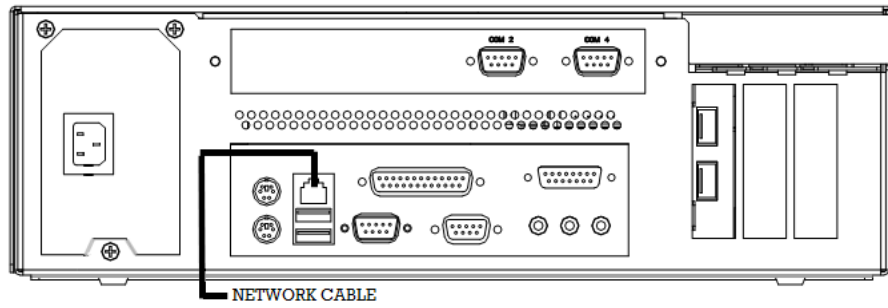

7. Plug the PC power cord into the receptacle on the rear of the PC and then into the wall outlet or optional Power Conditioner.

Figure 6: Rear View of PC

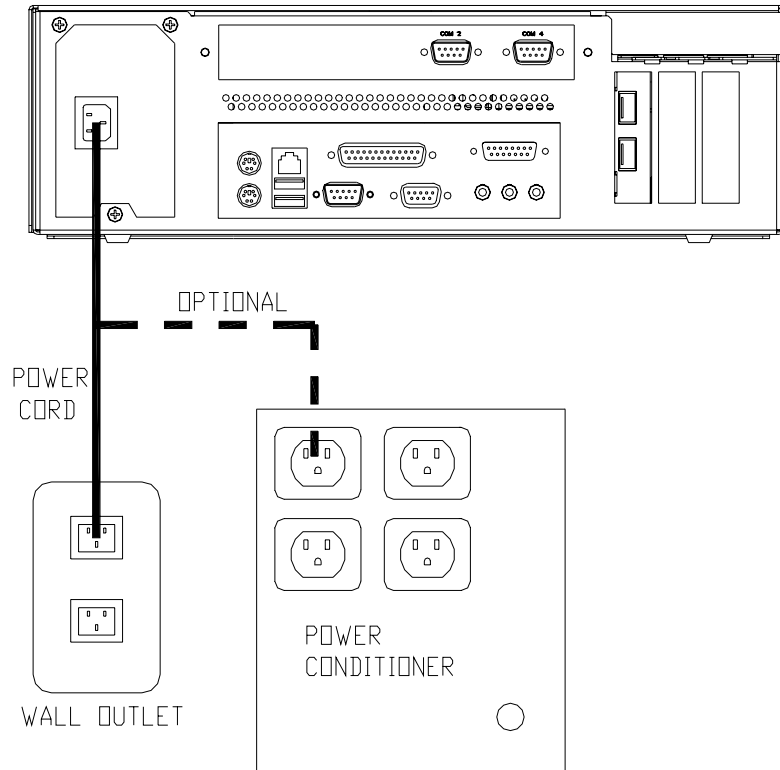

Powering On Your 2200 Series Back Office Workstation Bundle System

1. Remove the plastic protective sheets from the LCD Monitor.
2. Turn on the ATX PC power by depressing the on/off switch located on the front left-hand side of the PC.
3. To activate the monitor, depress the on/off switch located on the lower right hand side of the monitor bezel.

You have completed the installation of UTC RETAIL's 2200 Series Bundled Back Office Workstation System. If you experience problems with any of the components of the 2200 Series Bundled Back Office Workstation System, see the "Troubleshooting Procedures" section below.

Troubleshooting Procedures

The following table presents symptoms and solutions for problems potentially encountered when installing the 2200 Series Bundled Back Office Workstation System components.

Symptom	Solutions
There is no image on the LCD monitor.	<ul style="list-style-type: none">• Check to see if the monitor power cable is properly connected to the monitor.• Check to see if the SVGA cable is properly connected to the monitor.• Make sure that the LCD monitor power is on.
A keyboard error message displays when you boot the 2200 Series POS unit.	<ul style="list-style-type: none">• Check to see if the keyboard cable is properly connected to the keyboard.• Make sure that the keyboard cable is connected to the keyboard port (purple) on the logic unit, not to the mouse port (green).

Please call UTC RETAIL's Technical Support at 800.349.0546, if you have any problems not addressed in the Troubleshooting Procedures or have questions about other sections of this documentation.